

Monitoring Relays MRM

The MR monitoring relay was designed to monitor AC and DC signals in single-phase and three-phase systems and switch a relay based on configurable functions.

It supports monitoring TRMS currents/voltages, as well as frequency, phase angle, active power, apparent power, and power factor using automatic range selection for the best accuracy.

The single-phase model offers one measurement input and a single relay output (changeover contact rated at 6A/250V), while the three-phase version provides three measurement inputs and two independent relay outputs (changeover contact rated at 6A/250V). Both support fast and slow detection modes.

Continuous self-diagnosis ensures that alarms will be activated in the event of any malfunction or disturbance. The series is designed for user convenience, featuring clear display of measurements and parameters, all adjustable via a three-key menu. Alarm status is shown through a red LED indicator.

Functionality Overview

- **Wide Measuring Range:** Measures voltage (0.1–480 VAC / 0.1–690 VDC) and current (0.1–5 A) in 1- and 3-phase systems with automatic range detection.
- **Electrical Isolation:** Measuring inputs are fully isolated from the supply for reliable operation in complex installations.
- **Flexible Monitoring Functions:** Supports Min, Max and window functions with individual function assignment for each output.
- **Status Indication:** Provides clear LED feedback for each output and displays all operational states and parameter settings.
- **Simple Configuration:** Parameters are adjusted directly via the device display for fast and intuitive setup.
- **Secure Parameter Storage:** All settings remain stored during supply shutdown to ensure consistent operation after power return.
- **Compliance:**
 - EN 60947-1 Low-voltage switchgear and controlgear
 - EN 61000-6-2 Interference immunity
 - EN 61000-6-3 Interference emission
 - EN 50155 and EN 45545-2 Railroad vehicles (Railway versions only)

Safety

Read the enclosed instructions carefully before use! Disregarding the instructions may result in damage to equipment and/or serious personal injury.



This symbol indicates a risk of electrical hazards that could endanger personnel and infrastructure.

Ignoring this warning may result in **serious injury, death, equipment damage, or fire.**



This symbol indicates a required action to prevent damage to the device and surrounding equipment.

Failure to comply may result in **malfunctions, system failures, or equipment damage.**

CAUTION: Read carefully the enclosed instructions prior to use!

CAUTION: Electrical connection, starting up and operation has to be executed by qualified personnel only.



CAUTION: Read the manual attentively! Disregarding the instructions may result in damage to equipment and/or serious personal injury.

CAUTION: This device may not be used in areas subject to explosion hazards or in proximity to medical devices

CAUTION: Only mount and remove the MRx when the power supply is disconnected.

CAUTION: During electrical installation, comply with the usual standards and regulations.



WARNING: Keep sufficient clearance between the MRM and components which create magnetic fields to ensure accurate current measurements. For components such as contactors a minimal distance of 50 mm is recommended.

Content

Safety	2
Content	3
Type Designation	Fehler! Textmarke nicht definiert.
1. Monitoring, Response and Status Indication	4
1.1 Response Times	4
1.2 Measurement Ranges and Accuracy	5
1.3 Status Indication	6
2. Configuration	6
1.4 Factory settings	7
1.5 Operating instructions	7
1.6 Menu Navigation.....	9
3. Electrical Connection Diagram	10
4. Document History	11

Product Key

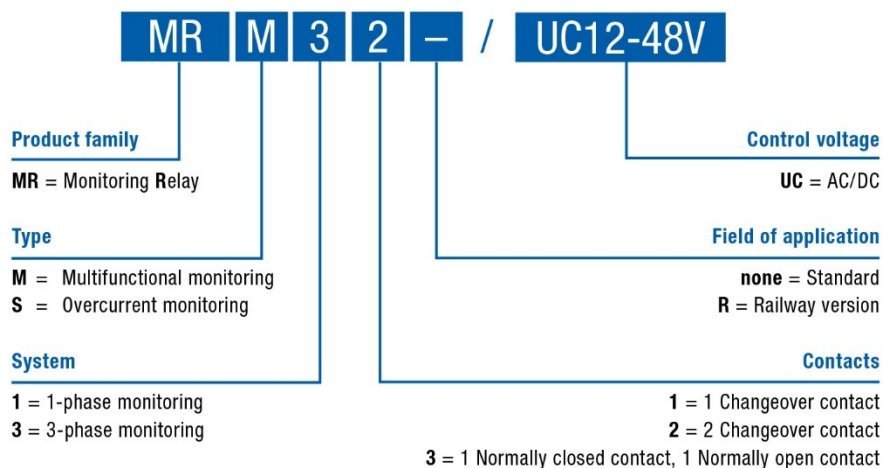

Please consult the MRM brochure for other variants or contact us for new configurations.

1. Monitoring, Response and Status Indication

The MRM device continuously measures the input value and compares it with the condition set by the user (alarm criteria). If the measured value violates the condition. i.e. a fault is detected, the alarm is triggered and relay is activated.

The following functions are available:

- **Over:** the alarm/relay is triggered when the measured value exceeds the set limit
- **Under:** the alarm/relay is triggered when the measured value falls below the set limit
- **Inside:** the alarm/relay is triggered when the measured value is within a set window.
- **Outside:** the alarm/relay is triggered when the measured value is outside a set window.

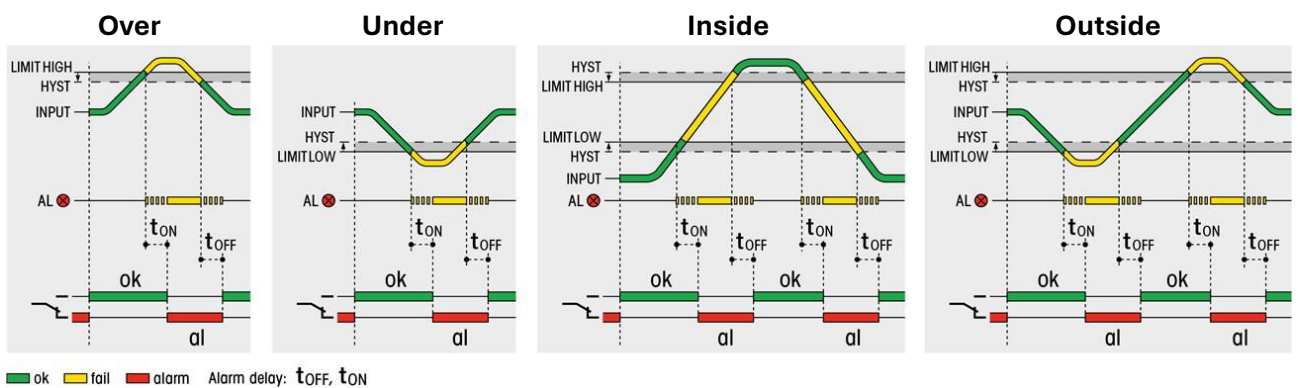

The MRM supports on-delay, off-delay and latching function when switching the relay(s). See Chapter 2 for details.

Hysteresis

Hysteresis (HYST) ensures stable recovery from an overcurrent condition. Once the current drops below a set threshold, it must fall below $|I_{Th} - (I_{Th} \times HYST)|$ before defaulting back to normal operation. This prevents unintended rapid switching between normal and fault states due to small variations in current near the threshold.

1.1 Response Times

The MRM devices support a slow and a fast detection mode.

	Fast mode	Slow mode
MRM11	60 - 120 ms	120 - 210 ms
MRM32	60 - 210 ms	120 - 660 ms

An on-delay and off-delay can be set by the user. Both values are configurable independently of each other in the range 0.5 to 999.9 s. Default setting is no delay.

1.2 Measurement Ranges and Accuracy

The below table lists the measurement ranges and errors. The errors apply to the slow mode and the entire temperature range.

Measurement	Measurement range AC	Measurement range DC	Adjustable range	Resolution	Max. measurement error AC		Max. measurement error DC	
					+/- % mean	+/- Unit	+/- % mean	+/- Unit
Voltage (U in V)	0 ... 480	-690 ... 690	-700 ... 700	0.1	2.0	0.2	0.5	0.1
Current (I in A)	0 ... 5	-5.0 ... 5.0	-6.0 ... 6.0	0.1	5.0	0.1	2.5	0.1
Frequency (f in Hz)	16 ... 100	--	15 ... 150	1	5.0	0.1	--	--
Phase angle ($\Delta\phi$)	0 ... 359	--	0 ... 359	1	$f * 0.2$	1.0	--	--
Active power (P in W)	0 ... 2400	-3450 ... 3450	-4200 ... 4200	1	5.0	0.2	2.5	0.2
Apparent power (S in VA)	0 ... 500	--	-4200 ... 4200	1	5.0	0.2	2.5	0.2
Power factor ($\cos\phi$)	0.00 ... 1.00	--	0.00 ... 1.00	0.05	5.0	0.1	--	--

It is also possible to monitor the phase sequence with the measurement of the phase angle. The recommended settings are: $\Delta\phi$ – Under – 100°





The frequency range for the fast mode is 46 ... 150 Hz.

The device allows setting limits outside the measurement range. For optimal performance it is recommended to select limits withing the specified measurement range.

Note that the measurement accuracy is low for very low current values. Therefore, current alarm limits below 0.3 A are therefore not recommended.

1.3 Status Indication

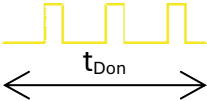
The table below lists how the alarm and relay status are indicated by the LED. This behaviour is the same for both relay outputs.

LED	Alarm State	Relay
Off 	OK (no alarm)	ON
Permanently on 	Alarm	OFF
Flashes rapidly 	Alarm on-delay in progress	ON
Flashes slowly 	No alarm off-delay in progress	OFF

2. Configuration

The MRM supports on-delay, off-delay and latching function when switching the relay(s).

On-Delay: The relay output switches **on after a defined delay** once the alarm criteria is met. If the input value returns to the normal range before the delay expires, the relay does not switch.

Off-Delay: The relay output switches **off after a defined delay** once the input returns to its normal range.

If the alarm criteria is met again before the delay expires, the relay does not switch off.

Latch Delay: The relay output switches when the alarm is triggered and stays on until manually reset (by pressing OK on the device).

The latching function can be combined with on-delay. On- and off-delay can be set independently of each other.

1.4 Factory settings

The MRM comes out of the box with the following default factory settings:

Monitoring	OFF
Scaling	OFF
Hysteresis	5.0 %
Delay	No delay

Other factory settings are available on request.

1.5 Operating instructions

- ▲ Increases the numeric value or moves to the next parameter.
- ▼ Decreases the numeric value or moves to the next parameter.
- OK Confirms the selected value and advances to the next menu item.
Press and Hold: Returns to the previous menu or exits menu without saving changes.
- ▲ ▼ Enters full menu
- ▼ OK Enters quick menu to only set the monitoring function from OFF to OVER

Menu Structure

- **Settings** contains all settings to configure the MRM according to Chapter 2.
- **Output test** allows switching the relay manually. The LED indicates the current state.
- **Device test** shows the internal temperature of the device, a reference voltage (for internal use only).
- **Factory reset** allows resetting all parameters to the factory settings.
- **Setup** configures the startup state and delay according to Chapter 7.
- **Infos** shows the firmware version of the device.

The **Quick Menu** allows to directly change the monitoring function from OFF to OVER. All other settings are accessible through the full menu (under settings).

Menu Behaviour

- The menu has a timeout period of 20 seconds; if no button is pressed, the device automatically returns to measurement mode without storing the last parameter entered. The display resets every five seconds, resulting in minor flickering.
- On the MRM32(R) model, the display cycles every two seconds per phase, whereas on the MRM11(R), it refreshes every 500 milliseconds during measurement mode. Upon exiting the menu, all parameters are saved; this process typically takes one second, during which monitoring is suspended and relay states remain static. The device will blink while saving parameters.
- Continuous self-diagnosis is integrated to guarantee that any malfunction or error triggers an immediate alarm. In such cases, the corresponding error code is shown on the display.
- Frequency measurement is based on the L1 voltage when it exceeds 1 V (TRMS). Power (P) is calculated when both $U > 1 \text{ V}$ and $I > 0.1 \text{ A}$; otherwise, apparent power (S) is set equal to P and the power factor (PF) is assigned a value of 1.
- In the absence of zero crossings in voltage or current, a minus sign is displayed for negative values (TRMS values are inherently positive). Each phase undergoes separate verification.
- The power factor is derived from apparent and active power values. If the frequency equals zero, active power is equated to apparent power, resulting in $PF = 1$.
- The accuracy of active power calculations may be compromised at lower sampling rates if the voltage or current waveforms deviate from sinusoidal. The precision of the power factor is affected accordingly.
- Numerical values exceeding 1000 are indicated with a 'k' prefix, with the maximum representable value being 9999 k (thousand) and the minimum being 0.001.
- The sum of phase angles is maintained at 360° , with measurements taken for L1 and L2, while L3 is deduced as $(360^\circ - L1 - L2)$. Compensation is applied for both relay switching and measurement cycle times during relay operation.

3. Electrical Connection Diagram

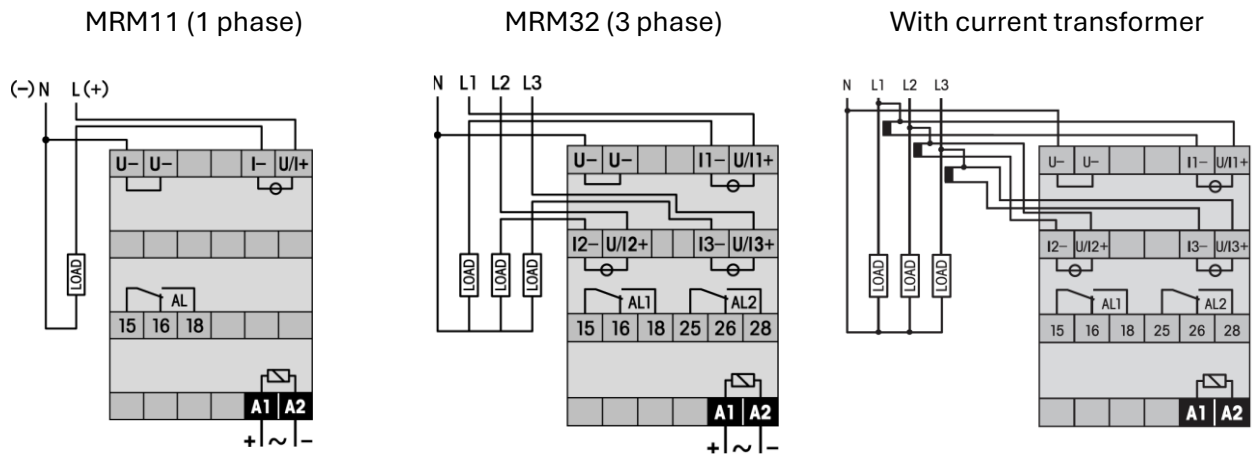

When using an MRM in combination with a current transformer, the transformer ratio can be set on the MRM device for automatic scaling. To enable this function, set parameter **Scaling** to **Yes** and set the **Scaling factor** to the transformer ratio. The maximum supported scaling factor is 100.

Note that the use of a current transformer might have an impact on the total response time as well as accuracy. Also ensure compliance with safety standard for installation and use of the current transformer.

4. Document History

This document is available in English, German, French and Italian. In the event of any discrepancies or ambiguities between translations, the English version serves as the authoritative reference.

Version	Details of changes	Release date
001	Initial versions	15.03.2012
002	Scaling factor, phase order, voltage withstand	13.07.2012
003	New layout	06.05.2014
004	Firmware V1.7	20.10.2014
005	Firmware V1.8	07.04.2015
006	Insulation	27.05.2015
007	New layout, consolidation MRU/MRI → MRM, use with current transformer	13.02.2026