

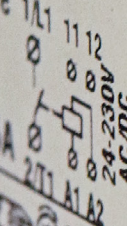

SOLID-STATE CONTACTORS



For frequent switching without contact bounce
 No wear and tear and silent operation thanks to semiconductor technology
 Non-hazardous switching of inductive loads
 Reduction of switch-on current thanks to zero voltage switching

Clear LED status display
 Integrated overload protection
 DIN rack or screw assembly
 Space-saving: standard module width from 22.5 to 90 mm
 Integrated cooling element with optional thermal protector

Contactor 1 Phase 1/L1 11 12
CC1H215
 230V AC max. 15A

 0.5Nm
 4.4lb-in
 0.5Nm
 4.4lb-in
 Break-circuit protection fuse:
 1 230 V
 2
 5
 EN 60947-4-3
 EN 60947-4-2
 Made in Germany

 47425

1/L1 11 12

 **comat RELECO**
 AC SC Contactor
CC1H215

U_e : 24-230V 50/60Hz
 I_e : Max.15A AC-1/AC-3
 U_c : 24-230V AC/DC
 U_i : 660V U_{imp} : 4kV



2/T1 A1 A2

1/L1 11 12

 **comat RELECO**
 AC SC Contactor
CC1H215

U_e : 24-230V 50/60Hz
 I_e : Max.15A AC-1/AC-3
 U_c : 24-230V AC/DC
 U_i : 660V U_{imp} : 4kV



2/T1 A1 A2

1/L1 11

 **comat RELECO**
 AC SC Contactor
CC1H215

U_e : 24-230V 50/60Hz
 I_e : Max.15A AC-1/AC-3
 U_c : 24-230V AC/DC
 U_i : 660V U_{imp} : 4kV

2/T1 A1 A2

Comat Releco solid-state contactors are used wherever almost infinite service life and a high number of switching cycles, high switching frequencies and silent switching is required.

Unlike mechanical contactors, the solid-state contactor does not show any signs of wear and tear. A lack of movable components prevents wear and creates resistance against vibrations. A varistor switch protects against damage caused by overvoltage. Comat Releco solid-state contactors have an integrated cooling element with optional thermal protector to provide a high degree of safety during operation. This feature creates great reliability, saves regular and expensive service work and prevents against costly system downtimes.

The solid-state contactors of the CC and CR series are available in single-phase, two-phase and three-phase design. They are designed for switching alternating current loads of up to 125 A at 400 V AC. The control voltage range is 24 to 230 V AC/DC.

The reversing contactor of the CCR series for motor loads up to 10 A has an integrated electronic interlock for both control Mechanical datas to prevent application errors.

The one-phase solid-state performance regulator CPC is suitable for triggering heating elements, lamps and transformers up to 50 A.

The solid-state contactors of the CC series are suitable for the non-contacting and non-wearing switching of resistive and inductive alternating loads with a high switching frequency. They are available with a max. operating voltage of 400V AC and a rated current of max. 63A in single-phase and three-phase design. The control voltage range 24–230V AC/DC is available.



	CC1H215	CC1H230 ^[1]	CC1H250 ^[1]	CC1H415	CC1H430 ^[1]	CC1H450	CC1H463 ^{[2] [3]}
--	---------	------------------------	------------------------	---------	------------------------	---------	----------------------------

Output

Switching element		Thyristor	Thyristor	Thyristor	Thyristor	Thyristor	Thyristor	Thyristor
Numbers of phases		1	1	1	1	1	1	1
Nominal voltage (U _{nom})	V AC	230	230	230	400	400	400	400
Output voltage range	V AC	12–240	12–240	12–240	24–480	24–480	24–480	24–480
Reverse voltage	V _{rrm}	1000	1000	1000	1200	1200	1200	1200
Peak reverse voltage	V _{rsm}	1100	1100	1100	1300	1300	1300	1300
Min. load	mA	10	10	10	10	10	10	10
Max. leakage current	mA	1	1	1	1	1	1	1
Operation current AC-1/51 @ U _{nom}	A	15	30	50	15	30	50	63
Operation current AC-3 @ U _{nom}	A	15	15	15	15	15	15	30
Operation current AC-55b @ U _{nom}	A	15	20	20	15	20	20	40
Operation current AC-56a @ U _{nom}	A	15	15	15	15	15	15	30
Response/Release time	ms	20	20	20	20	20	20	20
Limit load	A ² s	1800	1800	1800	1800	1800	1800	6300

Mechanical data

Dimension drawing		a	b	c	a	b	c	c
Cross section	mm ²	4	4	6	4	4	6	6

^[1] Also available for class B applications (CC1...H) | No approval

^[2] Availability on request

^[3] No approval

General data CC1 and CC3

Input: Voltage: 24–230 V AC/DC | Min. voltage: 20.4 V AC/DC | Max. voltage: 253 V AC/DC | Release voltage: 7.2 V AC/DC
 Max. current: 6 mA | **Insulation:** Insulation voltage: 4 kV | Dielectric strength: 660 V | **Approvals and conformities:**
Ambient conditions: Operating temperature: -5–40 °C | Storage temperature: -20–80 °C | Protection: IP20



Output

		CC3H410	CC3H420
Switching element		Thyristor	Thyristor
Numbers of phases		3	3
Nominal voltage (U_{nom})	V AC	400	400
Output voltage range	V AC	24–480	24–480
Reverse voltage	V _{rrm}	1200	1200
Peak reverse voltage	V _{rsm}	1300	1300
Min. load	mA	10	10
Max. leakage current	mA	1	1
Operation current AC-1/51 @ U_{nom}	A	10	20
Operation current AC-3 @ U_{nom}	A	10	10
Operation current AC-55b @ U_{nom}	A	10	10
Operation current AC-56a @ U_{nom}	A	5	5
Response/Release time	ms	20	20
Limit load	A ² s	610	610

Mechanical data

		b	c
Dimension drawing			
Cross section	mm ²	4	6

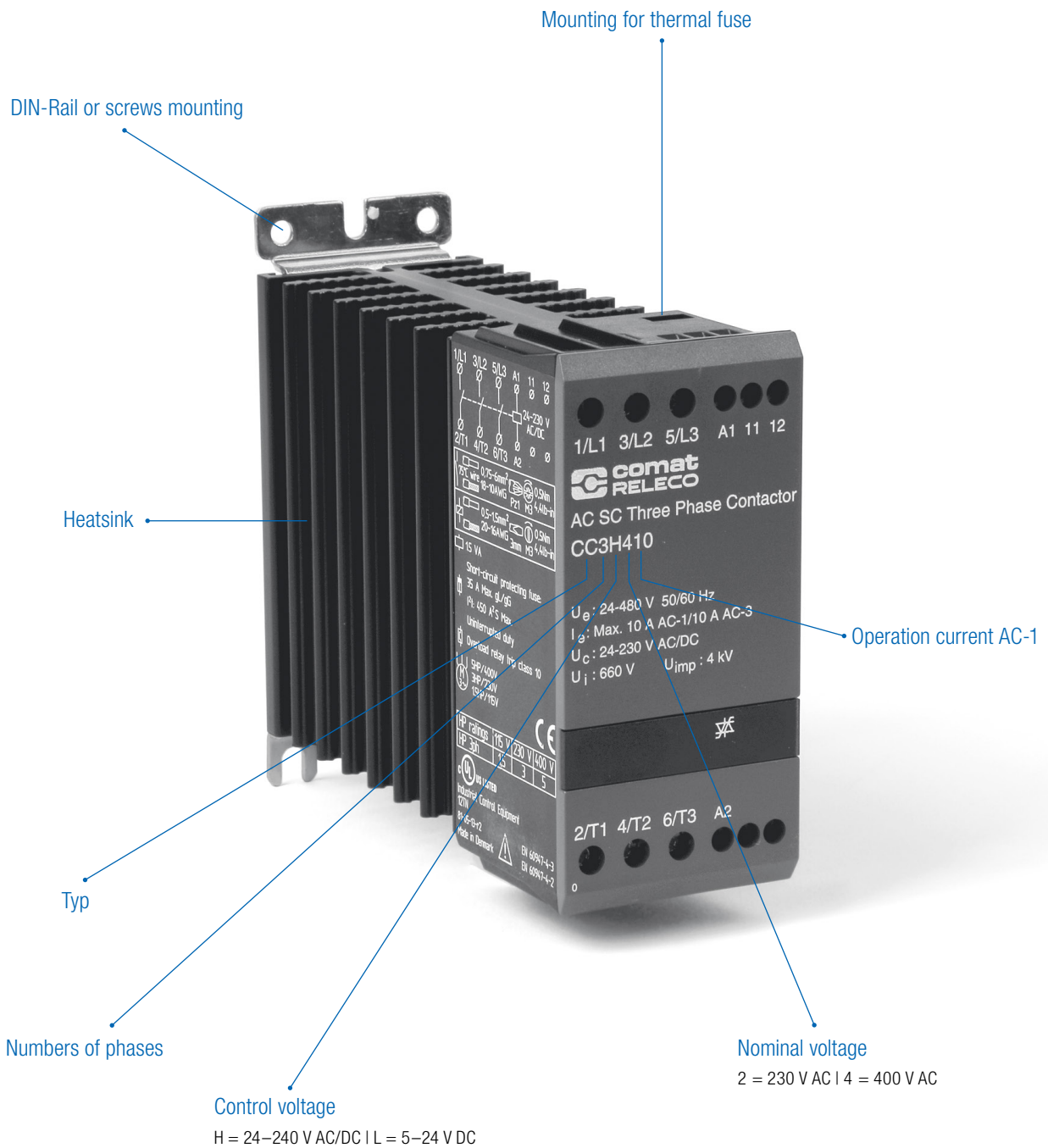

The CCR is a reversing contactor for asynchronous motors up to 10 A / 400 V AC. It has two separate electric control inputs for right and left motion that are interlocked. The control voltage range 24–230 V AC/DC is available.



CCR3H410

Output

Switching element		Thyristor
Numbers of phases		3
Nominal voltage (U_{nom})	V AC	400
Output voltage range	V AC	24–480
Reverse voltage	V _{rrm}	1200
Peak reverse voltage	V _{rsm}	1300
Min. load	mA	50
Max. leakage current	mA	5
Operation current AC-1/AC-51 @ U_{nom}	A	10
Operation current AC-53 @ U_{nom}	A	10
Response/Release time	ms	20
Limit load	A ² s	610

Mechanical data

Dimension drawing		b
Cross section	mm ²	4

General data CCR

Input: Voltage: 24–230 V AC/DC | Min. voltage: 20.4 V AC/DC

Max. voltage: 253 V AC/DC | Release voltage: 7.2 V AC/DC | Max. current: 6 mA

Insulation: Insulation voltage: 4 kV | Dielectric strength: 660 V | **Approvals and conformities:** $cULes$ [1]

Ambient conditions: Operating temperature: -5–40 °C | Storage temperature: -20–80 °C | Protection: IP20

[1] Use upstream mounted thermal protection

The one-phase solid-state performance regulator CPC is suitable for triggering heating elements, lamps and transformers up to 50 A. Performance is controlled through a potentiometer or analogue standard signal. The power supply takes place at 24 V DC.



		CPC1230	CPC1250	CPC1430	CPC1450
Output					
Switching element		Thyristor	Thyristor	Thyristor	Thyristor
Numbers of phases		1	1	1	1
Nominal voltage (U_{nom})	V AC	230	230	400	400
Output voltage range	V AC	208–230	208–230	400–480	400–480
Reverse voltage	V _{rrm}	1000	1000	1200	1200
Peak reverse voltage	V _{rsm}	1100	1100	1300	1300
Min. load	mA	10	10	10	10
Max. leakage current	mA	1	1	1	1
Operation current AC-1/AC-51 @ U_{nom}	A	30	50	30	50
Operation current AC-55b/56a	A	30	30	30	30
Response/Release time	ms	20	20	20	20
Limit load	A ² s	1800	1800	1800	1800

Mechanical data

Dimension drawing		b	c	b	c
Cross section	mm ²	4	6	4	6

General data CPC

Input: Voltage: 24 V AC/DC

Control signal: 0 – 10 V, 10 – 0 V, 0 – 20 mA, 20 – 0 mA, 4 – 20 mA, 20–4 mA, Potentiometer: 0 – 10 k Ω , 10 – 0 k Ω

Insulation: Insulation voltage: 4 kV | Dielectric strength: 660 V | **Approvals and conformities:** ^[1]

Ambient conditions: Operating temperature: -5–40 °C | Storage temperature: -20–80 °C | Protection: IP20

^[1] Use upstream mounted thermal protection

CC1

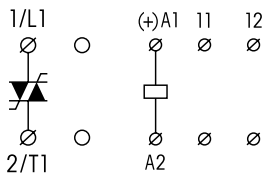

CC1...H

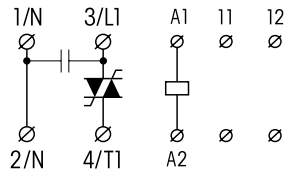

CR 11 H480

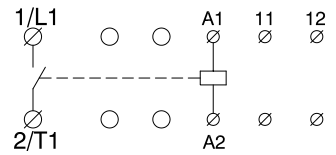

CR 11 H4125

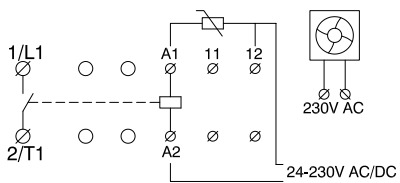

CR22

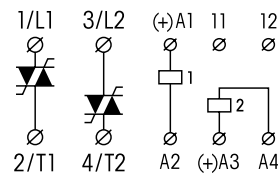

CC3 | CR33

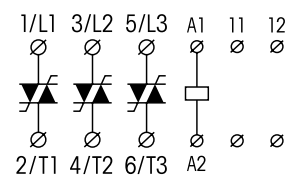

CPC

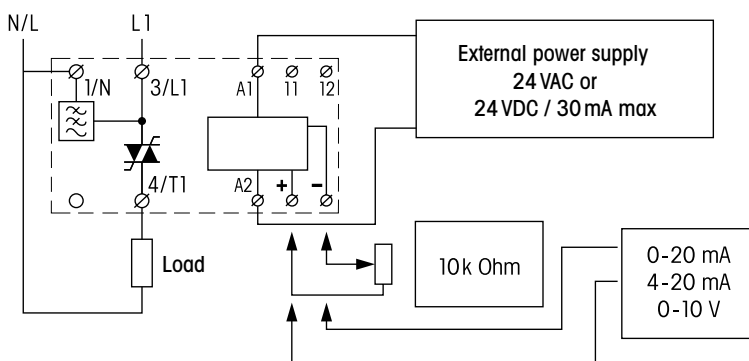

CCR

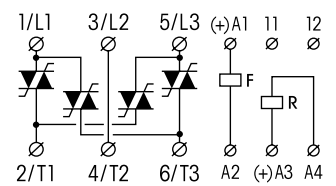

Dimensions

«Dimension drawing a» 22.5 mm module

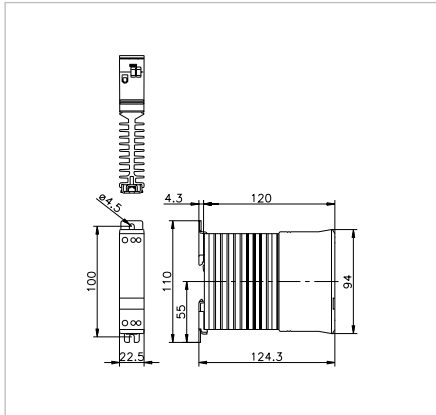

«Dimension drawing b» 45 mm module

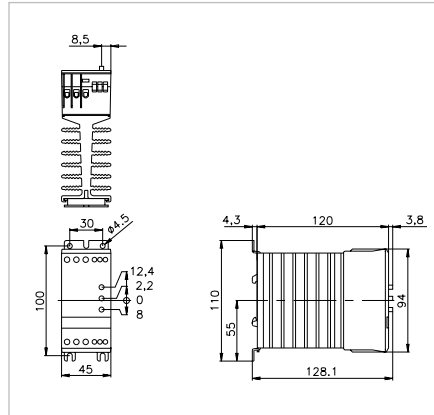

«Dimension drawing c» 90 mm module

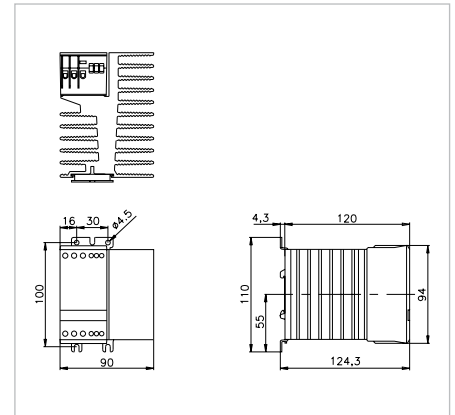

«Dimension drawing d» 90 mm module

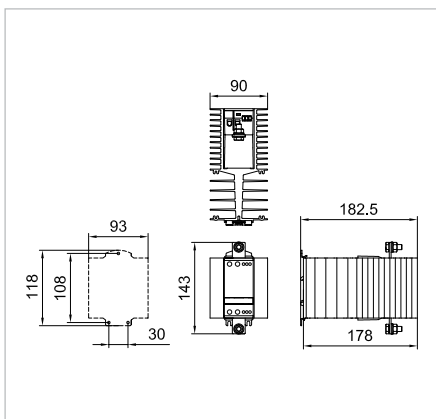

«Dimension drawing e» 90 mm module

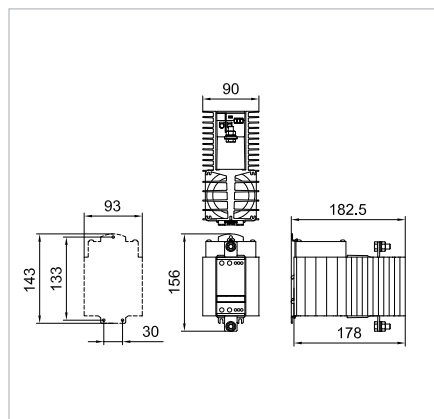

Mounting distances

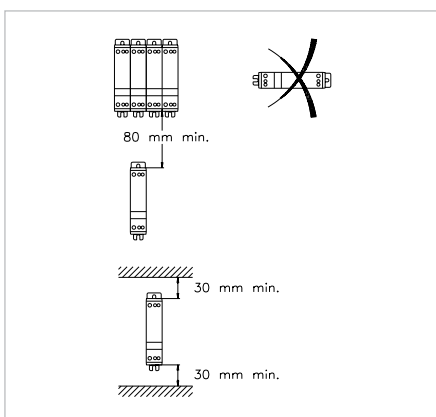

Thermal fuse P82-100C

