

Interface Relay

CRINT

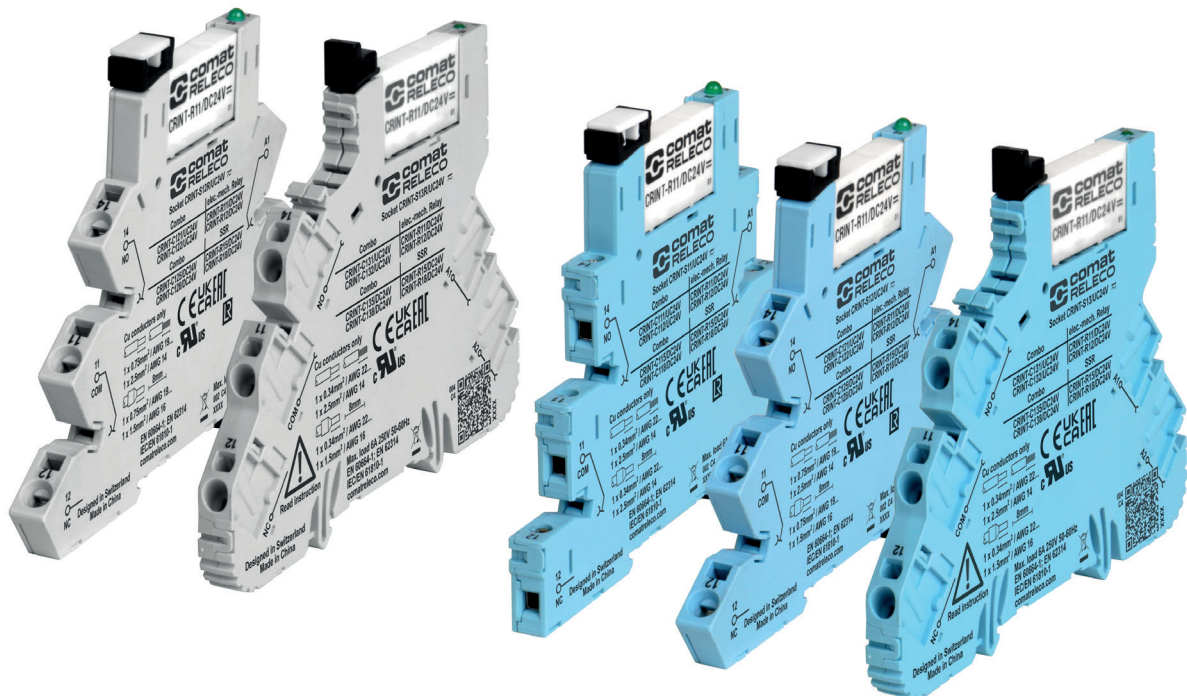

Interface Relay CRINT

- Electromechanical relay modules up to 6 A 250 V, different contact materials
- Solid state relay modules for most load types, up to 4 A 28.8 V DC, up to 2 A 280 V AC
- AC/DC, no protection circuit required
- LED status display
- Screw terminals, cage clamp terminals and push-in terminals
- Potential bridge bars
- Super small mounting: 6,2 mm width

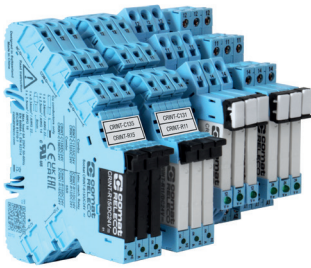

CRINT-C1x1



EMR-Interface module

For PLC's and process control. High power contact AgSnO₂. Available with screw terminals, cage clamp terminals or push-in terminals. Recommended max. load 250 V 6 A resistive.

6 A 250 V AC
100 mA / 12 V

CRINT-C1x2



EMR-Interface module

Specially for PLC, process controls with DC currents. Contact AgSnO₂ + Au. For low power application. Available with screw terminals, cage clamp terminals or push-in terminals.

6 A 250 V AC
10 mA / 12 V

CRINT-C1x5



MOSFET-interface module

For PLC's and process control. DC solid state switch, type NO. For fast and high frequent switching. Available with screw terminals, cage clamp terminals or push-in terminals.

4 A 24 V DC
20 mA / 12 V

CRINT-C1x8



TRIAC-interface module

For PLC's and process control. AC output interface zero synchronous switching NO for resistive or similar load. (No transformer rec.) Available with screw terminals, cage clamp terminals or push-in terminals.

2 A 240 V AC
100 mA / 12 V

Technical Data		CRINT-C1x1	CRINT-C1x2	CRINT-C1x5	CRINT-C1x8
	Contact type/material	CO / AgSnO ₂	CO / AgSnO ₂ + Au	NO / Solid-state DC	NO / Solide-state AC (triac)
	Rated load AC-1	1500 VA	1500 VA	–	480 W
	Switching power DC-1 24 V / 230 V	180 W	180 W	96 W	–
	Switching power AC-15	300 VA / 230 V	–	–	–
	Inrush current	15 A / 2.5 ms	15 A / 2.5 ms	48 A / 10 ms	80 A / 10 ms
	Switching cycles: mech./elec.	10 x 10 ⁶ / 3 x 10 ⁴	10 x 10 ⁶ / 3 x 10 ⁴	–	–
	Insulation open contact / contact – control	1 kV / 6 kV	1 kV / 6 kV	1 kV / 2.5 kV	1 kV / 2.5 kV
	Operating voltage range	0.8 ... 1.25 U _{Nominal}	0.8 ... 1.25 U _{Nominal}	0.8 ... 1.2 U _{Nominal}	0.8 ... 1.2 U _{Nominal}
	Power consumption AC / DC	0.9 VA / 0.4 W	0.9 VA / 0.4 W	160 mW	150 mW
	On delay / release time	7 ms / < 8 ms	7 ms / < 8 ms	≤ 50 μs / ≤ 300 μs	1/2 Cycle +1 ms / 1/2 Cycle +1 ms
	Operating temperature	-40...70 °C (-40...55 °C U _{Nominal} > 60)	-40...70 °C (-40...55 °C U _{Nominal} > 60)	-30...70 °C	-30...70 °C

CRINT-C1x1



CRINT-C1x2



CRINT-C1x5



CRINT-C1x8



CRINT screw terminals

Nominal voltage

AC / DC 12 V	CRINT-C111/UC12V	CRINT-C112/UC12V	CRINT-C115/DC12V	CRINT-C118/DC12V
AC / DC 24 V	CRINT-C111/UC24V	CRINT-C112/UC24V	CRINT-C115/DC24V	CRINT-C118/DC24V
AC / DC 48 V	CRINT-C111/UC48V	CRINT-C112/UC48V	CRINT-C115/DC48V	–
AC / DC 60 V	CRINT-C111/UC60V	CRINT-C112/UC60V	CRINT-C115/DC60V	CRINT-C118/DC60V
AC / DC 110–125 V	CRINT-C111/UC110-125V	CRINT-C112/UC110-125V	CRINT-C115/DC110-125V	CRINT-C118/DC110-125V
AC / DC 220 – 240 V	CRINT-C111/UC220-240V	CRINT-C112/UC220-240V	CRINT-C115/DC220-240V	CRINT-C118/DC220-240V

CRINT cage clamp terminals

Nominal voltage

AC / DC 12 V	CRINT-C121/UC12V	CRINT-C122/UC12V	CRINT-C125/DC12V	CRINT-C128/DC12V
AC / DC 24 V	CRINT-C121/UC24V	CRINT-C122/UC24V	CRINT-C125/DC24V	CRINT-C128/DC24V
AC / DC 48 V	CRINT-C121/UC48V	CRINT-C122/UC48V	CRINT-C125/DC48V	–
AC / DC 60 V	CRINT-C121/UC60V	CRINT-C122/UC60V	CRINT-C125/DC60V	CRINT-C128/DC60V
AC / DC 110–125 V	CRINT-C121/UC110-125V	CRINT-C122/UC110-125V	CRINT-C125/DC110-125V	CRINT-C128/DC110-125V
AC / DC 220 – 240 V	CRINT-C121/UC220-240V	CRINT-C122/UC220-240V	CRINT-C125/DC220-240V	CRINT-C128/DC220-240V

CRINT push-in terminals

Nominal voltage

AC / DC 12 V	CRINT-C131/UC12V	CRINT-C132/UC12V	CRINT-C135/DC12V	CRINT-C138/DC12V
AC / DC 24 V	CRINT-C131/UC24V	CRINT-C132/UC24V	CRINT-C135/DC24V	CRINT-C138/DC24V
AC / DC 48 V	CRINT-C131/UC48V	CRINT-C132/UC48V	CRINT-C135/DC48V	–
AC / DC 60 V	CRINT-C131/UC60V	CRINT-C132/UC60V	CRINT-C135/DC60V	CRINT-C138/DC60V
AC / DC 110–125 V	CRINT-C131/UC110-125V	CRINT-C132/UC110-125V	CRINT-C135/DC110-125V	CRINT-C138/DC110-125V
AC / DC 220 – 240 V	CRINT-C131/UC220-240V	CRINT-C132/UC220-240V	CRINT-C135/DC220-240V	CRINT-C138/DC220-240V

CRINT Product Key

1		2	3	4	5	6		7	8
CRINT	-	C	1	3	1	R	/	UC	24V

1. Product family

2. Type

C = Combined version (Socket and Relay)

R = Relay

3. Contact

1 = One change-over contact

2 = Two change-over contact

3 = One change-over contact, dual terminal

4. Connection type

1 = Screw terminal

2 = Cage clamp terminal

3 = Push-in

5. Output

1 = AgSnO₂

2 = AgSnO₂ + Au

3 = AgNi

4 = AgNi + Au

5 = NO / Solid-state DC

8 = NO / Solid-state AC

6. Options

without = Standard version

R = Railway version

7. Supply voltage

UC = AC/DC

DC = Only for C1x5 and C1x8

Relay Product Key

1		2	3	5		7	9
CRINT	-	R	1	1	/	DC	12V

8. Nominal control voltage CRINT (AC / DC)

12 V, 24 V, 48 V, 60 V, 20-100 V, 24-80 V,

110-125 V, 220-240 V

9. Nominal control voltage relay (DC)

12 V, 24 V, 48 V, 60 V*, 110 V**

*CRINT-R1x: 60 V relay used for all sockets with a nominal voltage ≥ 60 V

**CRINT-R2x: 110 V relay used for all sockets with a nominal voltage ≥ 110 V

Accessories

Potential bridge bar
 CRINT-BR20-BK (black)
 CRINT-BR20-BU (blue)
 CRINT-BR20-RD (red)

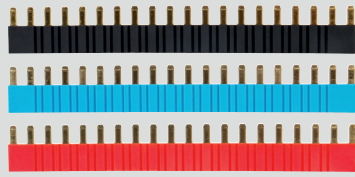

Label plate
 CRINT-LAB



Marking strip for push-in CRINT
 BS11-PI (50m)



Spacer
 CRINT-SEP



Replacement Relays

CRINT-R11

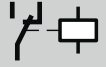

CRINT-R12

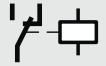
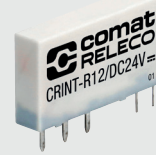

CRINT-R15

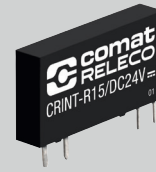

CRINT-R18

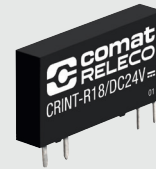

Dimensions

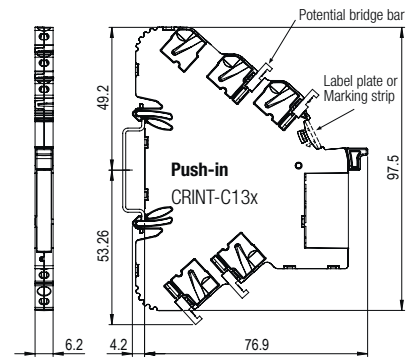
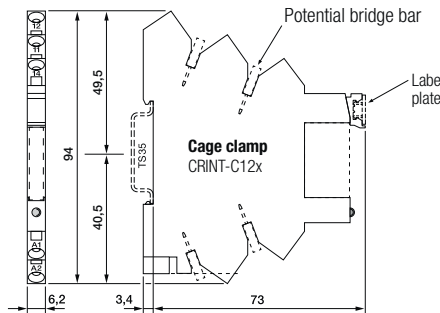
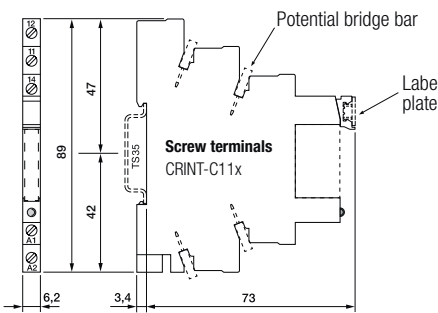

Approvals

